



Type SCH94

- \varnothing 94 Hollow Shaft Encoder
- Hollow Shaft \varnothing 12 mm, \varnothing 16 mm or \varnothing 17 mm
- Heavy duty ball bearings
- IP 66 (IP 65 & IP 67 options)
- Built-in Transient Suppression module

Electrical Specifications	
Code:	Incremental
Resolution:	1 to 12,500 ppr (pulses per revolution)
Supply Voltage:	4.5V - 30V
Current Consumption:	45 mA max. (no load)
Supply Voltage and Output Specifications for various Output Standards:	TTL: $V_{sup} = 5V \pm 10\%$ $V_{high} \geq 4.3V @ I_{out} = -16 mA$ $V_{low} \leq 0.5V @ I_{out} = 16 mA$
	RS422: $V_{sup} = 5V \pm 10\%$ Min. diff. load (Z_o): 100 Ω $V_{diff.} \geq 2.9V @ Z_o = 100 \Omega$ $V_{high} \geq 3.8V @ Z_o = 100 \Omega$ $V_{low} \leq 0.9V @ Z_o = 100 \Omega$
	HTL: $V_{sup} \geq 9V - 30V$ $V_{high} \geq V_{sup} - 1.8V @ I_{out} = -20mA$ $V_{low} \leq 0.8V @ I_{out} = 20 mA$
Output Current:	40 mA max. load per output channel
Frequency Response:	300 kHz max.; 100 kHz with TSM
Output Format:	Two channel (A, B) quadrature with Index (Z) and complementary (A-, B-, Z-) outputs
Phase Sense:	A leads B clockwise (CW) from the shaft end of the encoder
Index:	Gated with Channels A and B high
Accuracy:	+/- 0.8 arc-min.
Output:	OL7272 Line Driver HTL, TTL and RS422 compatible
Electrical Protection:	Output short circuit, reverse polarity (MS output only) and transient surge protected through built-in protection module (see TSM details on website)
Noise Immunity:	Tested to EN61000-6-2 : 2005 (industrial environments) and EN 61000-6-3 : 2007 (residential, commercial, and light-industrial environments) for Electromagnetic compatibility (EMC)

Mechanical Specifications	
Material:	Housing: Aluminum Cap: Aluminum Hollow shaft: Stainless Steel (AISI 303)
Weight:	Encoder: approx. 925 gr. (32.65 oz)
Bearing Life:	> 1.9×10^{10} revolutions at rated load
Shaft Speed:	2,200 rpm max. IP 66 (IP 67 option) 3,000 rpm max. (IP 65 option)
Starting Torque:	< 0.1 Nm (14.16 oz-in) at 25° C
Mass Moment of Inertia:	31 gcm ² (4.39×10^{-4} oz-in-sec ²)
Shaft Loads:	Axial 200 N (45 lbs) max. Radial 400 N (90 lbs) max.

Environmental Specifications	
Operating Temperature:	-40° to +85° C
Storage Temperature:	-40° to +85° C
Shock:	100 G / 11 ms
Vibration:	(10-2000 Hz) / 10 G
Bump:	10 G - 16 ms (1000 x 3 axis)
Humidity:	98 % RH without condensation
Enclosure Rating:	IP 66 / Nema 6 (approx.) IP 67 / Nema 6 (approx.) option IP 65 / Nema 4 (approx.) option chromitAL TCP passivation
Non-conductive Hollow Bore	Non-conductive ceramic insert for shaft insulation; up to 2.5 kV

Connection Options	
Cable:	8 leads (0.75 mm ² , 19 AWG) twisted pairs; shielded; halogen free
Connectors:	9-lead terminal blocks (inside cap) M20 cable gland (fits cable \varnothing 8 - 14 mm) 12-pin M23 connector

Output waveform

Disk Resolutions (pulses per revolution)

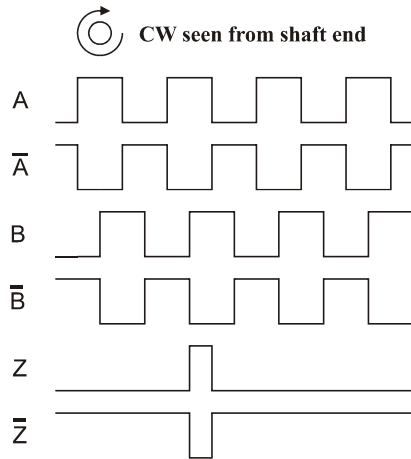

746	1024	2048	2500	3072
4096				

Other resolutions manufactured upon request

Channel tolerance $180\text{ e}^\circ \pm 36\text{ e}^\circ$
 Phase difference tolerance $90\text{ e}^\circ \pm 18\text{ e}^\circ$
 Z channel tolerance $90\text{ e}^\circ \pm 18\text{ e}^\circ$

Mechanical Dimensions

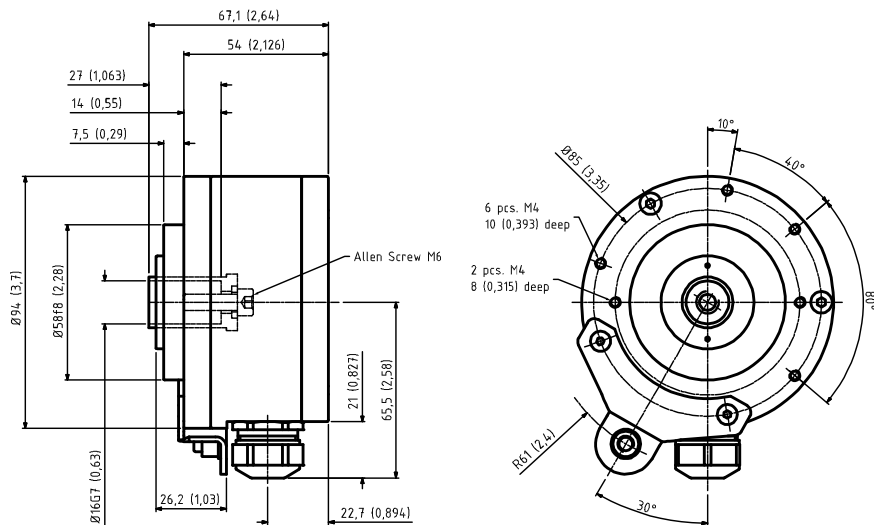

Recommended mating shaft
 Max. radial run out +/- 0,1

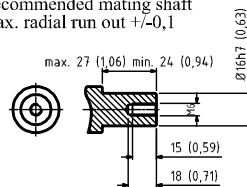

Standard Cable Gland

mm (inches)

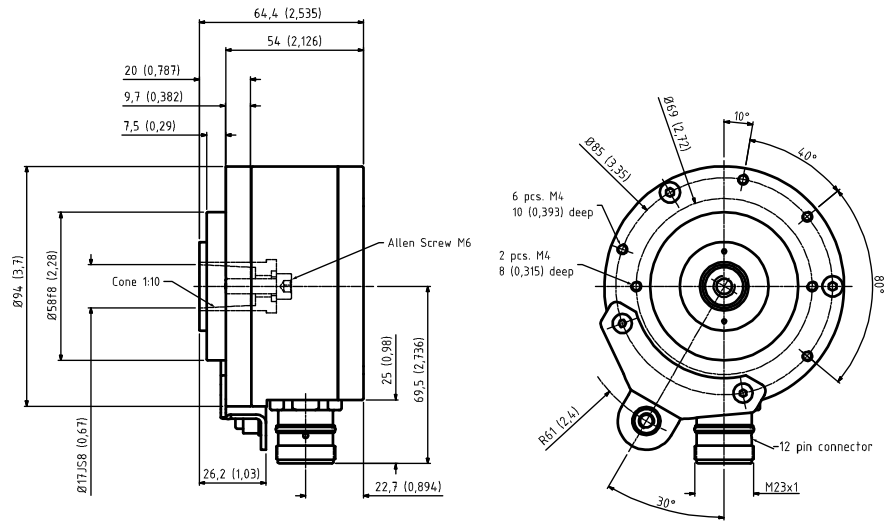

Recommended mating shaft
 Max. radial run out +/-0,1

M23 connector

mm (inches)

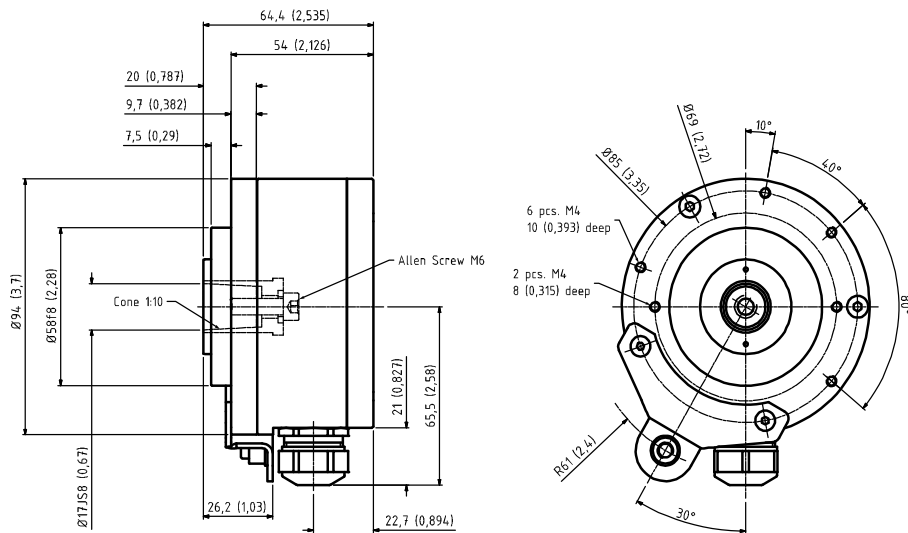
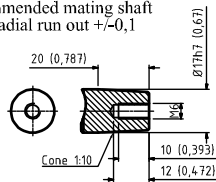

Recommended mating shaft
 Max. radial run out +/-0,1

Standard Cable Gland

mm (inches)

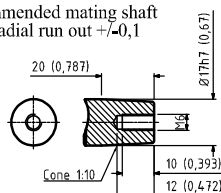

Output Terminations

Removable End Cap

Position	Terminal Block	
	Standard Output	Differential Output
	Channel	Channel
1	GND	GND
2	Vcc	Vcc
3	Shield	Shield
4	A	A
5	*	A -
6	B	B
7	*	B -
8	Z	Z
9	*	Z -

* Do not attach any wires to terminal block

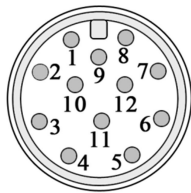
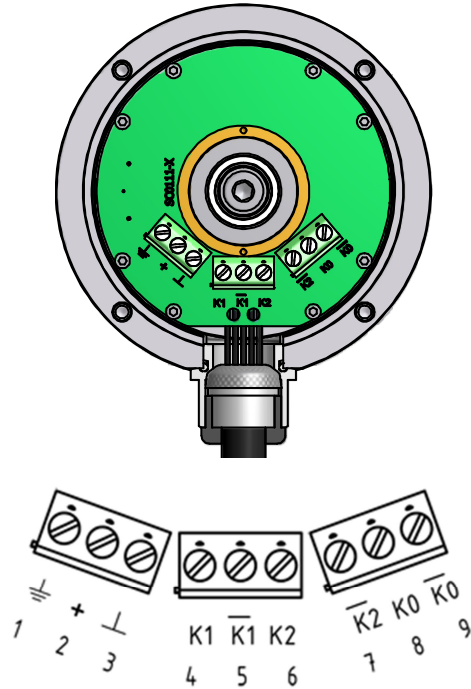

M23 Connector	
Pin	Channel
1	Ch. B -
2	N/C
3	Ch. Z
4	Ch. Z -
5	Ch. A
6	Ch. A -
7	N/C
8	Ch. B
9	N/C
10	0 Volt
11	N/C
12	Vcc

Channel	Standard Cable	
	Standard Output	Differential Output
Channel	Wire Color	Wire Color
A	Pink	Pink
A -	Gray*	Gray
B	Green	Green
B -	Yellow*	Yellow
Z	White	White
Z -	Brown*	Brown
Vcc	Red	Red
Ground	Blue	Blue

* Gray, Yellow, and Brown are internally connected to Circuit Ground

Ordering Code

Example: SCH94 – 3072 – MS – 17 – 20 – 66 – 00 – CG1

Type

